

Assessment of the Gas Potential and Yields from Shales: the Barnett Shale Model

Daniel M. Jarvie¹, Ronald J. Hill², and Richard M. Pollastro²

¹Humble Geochemical Services, P.O. Box 789, Humble, Texas 77347, danjarvie@humble-inc.com

²United States Geological Survey, Box 25046, MS 977, Denver, CO 80225

Abstract

The Newark East gas field in the Ft. Worth Basin, Texas, is now the largest producing gas field in the State of Texas. Production of gas is primarily from the Mississippian Barnett Shale. While gas and some oil are produced from horizons younger and older than the Barnett Shale, the bulk of gas production comes from the low porosity (*ca.* 6%) and low permeability (*ca.* 0.02 mD) shale itself. Thus, the Barnett Shale functions as the source, reservoir, and seal with regard to the Total Petroleum System.

There are several key components to geochemical evaluation of the Barnett Shale play including assessment of organic richness, original hydrocarbon potential, thermal maturity, gas content, gas yields, secondary cracking of oil to gas, and burial history models.

Overall, assessing gas prospects in the Barnett Shale from a geochemical perspective requires risking geochemical data, primarily those data related to, or a function of, the maximum thermal heating of the organic matter. Risking parameters such as TOC, vitrinite reflectance, Tmax, kerogen transformation ratios, and gas dryness can be used to assess prospects and lease areas for potential commercial gas yields from the Barnett Shale.

The Barnett Shale was originally a Type II oil prone kerogen based on hydrogen indices. In the main gas fairway the kerogen is highly mature and gas is derived both from kerogen cracking and oil-to-gas cracking.

Burial history modeling suggests that most hydrocarbons were generated about 250 m.a.b.p., although some hydrocarbons could have been generated as recently as 25 m.a.b.p. There is no present-day hydrocarbon generation and the main phase of hydrocarbon generation likely occurred 250 m.a.b.p.

The Barnett Shale has very high gas yields ranging from 170-250 scf/ton based on corrected methane adsorption data from the T.P. Sims #2 well. This gas is present as 55% free gas and 45% sorbed gas, on average.

Introduction

The Ft. Worth Basin is a Paleozoic basin formed as a result of the advancing Ouachita Thrust belt. The basin margins are delimited by the Red River and Muenster arches in the north, the Bend Arch in the west, the Llano Uplift in the south, and the Ouachita structural front in the east (Fig. 1).

Evidence of the Mississippian Barnett Shale source and gas potential is provided by correlation of oil and gas to Barnett Shale source rocks. Its geochemical characteristics are further assessed by determination of the quantity of organic matter (organic richness or TOC value), its original hydrocarbon generation potential, its degree of conversion or transformation from kerogen to oil and gas including rates of secondary cracking of oil to gas, gas composition, carbon isotopes, and gas calorific value, gas yields per unit of shale, and burial and thermal history modeling.

The Barnett Shale Paleozoic Total Petroleum System is used to describe gas and oil generated by the Barnett Shale that is found in Paleozoic reservoirs in the Ft. Worth Basin (Pollastro, 2003; Pollastro et al., 2003). This terminology is adapted from the U.S. Geological Survey description of a petroleum system that includes an effective source rock, known accumulations, and an area of undiscovered hydrocarbon potential (Magoon and Schmoker, 2000). The Mississippian Barnett Shale serves as source, reservoir, and seal to gas and petroleum in the Ft. Worth Basin, Texas and since 2002, the Newark East Field has become the largest gas field in the State of Texas.

Gas production from tight shales requires cracking of oil that has been generated from indigenous organic matter, otherwise the low porosity and permeability of the shale will be occluded. When thermal maturity levels exceed about 1.0% to 1.20% vitrinite reflectance, gas content increases rapidly due to secondary cracking of oil to gas. When cracking occurs, GOR (gas-to-oil ratios) and gas flow rates increase dramatically resulting in vertically drilled wells with high flow rates (500-2000 MCFD) and much higher rates in horizontally drilled wells.

The source of oil and gas in the Ft. Worth Basin

A detailed study of Ft. Worth Basin oils and gases is currently underway as a joint effort by the U.S. Geological Survey and Humble Geochemical Services. Oil and gas data have been reported, however, and the data show that the Barnett Shale is the source of the oil and gas in the basin (Jarvie et al., 2001; Jarvie et al., 2003; Hill et al., 2004, Jarvie et al., 2004). For example, oil fingerprinting results show that the oils are very similar in isoprenoid biomarker ratios (Fig. 2). More detailed analyses of the oils show that there may be organofacies differences within the Barnett Shale. The majority of oils have a low sulfur marine shale signature, whereas there are others that have a terrestrial component and perhaps marl lithofacies component that slightly alter the molecular composition of the oil. Barnett Shale sourced oils are found in horizons older (Ordovician Ellenburger) and younger (Pennsylvanian Strawn, Conglomerate, etc.) than the Barnett Shale.

Analysis of gas samples from the Pennsylvanian Boonsville conglomerate and within the Barnett Shale appear to be sourced by the Barnett Shale (Jarvie et al., 2003). Gas in the Boonsville conglomerates (the horizon of original production prior to shale development) is wetter and of lower thermal maturity than gas produced from the Barnett Shale (Jarvie et al., 2003). It is likely that the Boonsville gases are oil-associated gases, i.e., gas co-

generated from kerogen with oil within the oil window, whereas the producible gas contained within the Barnett Shale is derived from cracking of oil at higher thermal maturities. Thus, it is known that the Barnett Shale has expelled some hydrocarbons both as oil and gas.

Analysis of well samples, including cuttings and sidewall core, from wells across the Ft. Worth Basin show that the Barnett Shale is the primary source rock. While other horizons show limited source potential, correlation of oils to both oil produced from the Barnett Shale and rock extracts of the Barnett Shale confirm it as the source of most of the oil and gas produced in the basin (Jarvie et al., 2001; Jarvie et al., 2003). Oils produced from low maturity Barnett Shale in Brown County correlate with other oils in the western portion of the basin such as Shackelford, Callahan, and Throckmorton counties based on gas chromatographic analysis, biomarkers, and carbon isotopes (Jarvie et al., 2003; Hill et al., 2004). These same oils correlate with condensates in the central producing horizons of the Newark East Field based on light hydrocarbons, biomarkers, and carbon isotopes (Jarvie et al., 2001; Jarvie et al., 2004; Hill et al., 2004).

Barnett Shale Source Rock Potential and Thermal Transformation

In order to evaluate the geochemical characteristics of the Barnett Shale, numerous well and outcrop samples were analyzed. The wells are located in various points around the basin representing immature to highly converted Barnett Shale organic matter (see Fig. 1, well designations). The Lampasas outcrop sample and the Mitcham #1 well in Brown County in the south-southwest portion of the basin represent low maturity Barnett Shale. In the Montague County to the north, the Truitt #1 and Grant #1 well are representative of Barnett Shale in the oil window, and in the heart of the gas productive area, the Sims #2, Young #1, Oliver #1, and Gage #1 wells are typical of wells in the wet to dry gas windows (see Fig. 1, Table 1).

Average TOC (total organic carbon), hydrogen indices (HI), calculated and measured vitrinite reflectance values (%VR_o), and calculated transformation ratios (TR in %) are shown in Table 1, and a modified Espitalie kerogen type and maturity plot (Espitalie et al., 1984) is shown in Figure 3. It is inferred from the data trend in Figure 3 that the Barnett Shale was originally a Type II oil prone marine shale and was not originally either a Type III gas prone kerogen or a Type I kerogen as has been cited from time-to-time. With increased thermal maturation, the Barnett Shale is essentially converted from a Type II into a Type III source rock. Carbon and hydrogen loss are due to hydrocarbon generation, thereby reducing the original source potential of the rock. This maturation trend is shown in Figure 3, where the decrease in HI values follows a trend of increasing thermal maturity. The maturity trend line changes from the lowest maturity outcrop sample to well samples of the very high, gas window maturity Gage, Sims, and Oliver Barnett Shale HI values.

Organic richness of the Barnett Shale is excellent having high commercial source potential (Jarvie, 2000). In addition, high storage capacity of the Barnett Shale for gas is related to its organic richness. The average total organic carbon (TOC) value determined

on low maturity (Rock-Eval T_{max} < 435°C) Barnett Shale formation cuttings is 3.26%, with an average generative potential of 7.86 mg HC/g rock or approximately 172 barrels of oil per acre-foot (BO/AF) or 172 MCF/AF (Jarvie et al., 2001; Pollastro, 2003). However, these values are from cuttings samples and are likely diluted based on mixing with massive carbonates above the Barnett Shale. On a single well, where cuttings and conventional core analysis were compared for TOC values, the TOC values on the core samples were 2.36 times higher than cuttings samples (Jarvie *unpublished data*). The dilution effect on cuttings samples also indicates that other geochemical parameters measured from cuttings are lower than those measured on core, including remaining generation potential and thermal maturity. This is due primarily to cavings. Hand picking of samples does not change the values, as even lean carbonates visually appear as dark gray to black in color.

An evaluation of the hydrocarbon charge from the Barnett Shale requires a volumetric assessment of the original hydrocarbon generation potential. In the thermal limits of the gas window, the remaining generation potentials (Rock-Eval S₂ values) only represent the yield of hydrocarbons that could be obtained from additional maturation or cracking of Barnett Shale. Thus, it is important to reconstruct the original hydrocarbon source potential. This is accomplished by evaluating low thermal maturity source rocks of the Barnett Shale.

Organic rich, low thermal maturity outcrops of the Barnett Shale found near Lampasas, Texas have TOC values as high as 13% with a generation potential of 60.62 mg HC/g rock (Rock-Eval S₂) or 1327 BO/AF. Five outcrop samples from the J.R. Walker Ranch average 8.85% and average 30.28 mg HC/g rock or 662 BO/AF for generation potential. In addition, organic rich, low thermal maturity well cuttings measured from the Jones Co. Mitcham #1 well have Barnett Shale that has 5.21% average TOC, with generation potentials of 19.80 mg HC/g rock (433 BO/AF). However, despite being low thermal maturity (*ca.* 0.60% vitrinite reflectance), this well produces a high quality (38° API gravity, low sulfur) oil from the Barnett Shale, which is generated *in situ*. Thus, some generation and internal expulsion of hydrocarbons has occurred even at this low thermal maturity.

Cuttings from the Mitcham #1 well were artificially matured in the laboratory to evaluate the rates of decomposition for the Barnett Shale in an attempt to simulate organic matter transformation in nature (Jarvie and Lundell, 1991). While this extrapolation is orders of magnitude from the laboratory compared to the natural geological environment and time frame, the data correlate well to data for more mature Barnett Shale. These data sets were then used to determine the change in geochemical parameters with maturation (albeit laboratory-induced) and then used as predictive tools. TOC is reduced by approximately 36% from its original value (Jarvie and Lundell, 1991; Montgomery et al., 2004), but the remaining potential and hydrogen index are reduced by over 90%, indicative of a high degree of conversion of organic matter to hydrocarbons and a carbonaceous residue.

For comparison to the geological setting, a well in Eastland County, the Alice E. Allen Heirs #1 well, was chosen. The location of this well is down dip from the Mitcham #1 well and thus has been exposed to a much higher thermal history as evidenced by lower HI value and higher Tmax (Fig. 4). The calculated vitrinite reflectance value based on the formula of Jarvie et al. (2001) is:

$$\text{Cal. \%VR}_o \text{ (from Tmax)} = 0.0180 \times \text{Tmax} - 7.16 = 1.01\% \text{VR}_o \text{ (cal.)}$$

placing the Barnett Shale in this well in the latest oil – earliest condensate/wet gas window. Guidelines from thermal maturity assessments for the Barnett Shale are suggested as follows:

<u>Cuttings VR_o values</u>	<u>Maturity</u>
< 0.55% VR _o	Immature
0.55% to 1.00% VR _o	Oil Window (Peak oil at 0.90%VR _o)
1.00 to 1.40% VR _o	Condensate-wet gas window
>1.40% VR _o	Dry gas window
<u>Core VR_o values</u>	<u>Maturity</u>
< 0.55% VR _o	Immature
0.55% to 1.15% VR _o	Oil Window (Peak oil at 0.90%VR _o)
1.15 to 1.40% VR _o	Condensate-wet gas window
>1.40% VR _o	Dry gas window

There is a gray area in the 1.00 to 1.20% vitrinite reflectance range, but 1.20% is certainly in the condensate-wet gas window and in the gas-productive sweet spot.

The Heirs #1 well has a calculated original TOC of 5.31% (i.e., present-day TOC / 0.64). This is what would be expected for an equivalent facies of the Barnett Shale, which it appears to be. The change in TOC for the Heirs #1 well is a result of hydrocarbon generation, so the original generation potential can be calculated using an average value of carbon in hydrocarbons (83%), converting weight percent to mg hydrocarbons / g rock (ppt), and adding the present-day remaining potential (S2=2.31):

$$\text{TOC}_{\text{change}} = \text{TOC}_{\text{original}} - \text{TOC}_{\text{present}} = 1.91 \text{ wt. \%}$$

$$\text{TOC}_{\text{change}} / 0.083 = 1.91 / .083 + 2.31 = 25.35 \text{ mg hydrocarbons/g rock (original S2)}$$

It then follows that the original HI value is

$$\begin{aligned} \text{Original HI} &= \text{Original S2} / \text{Original TOC} \times 100 \\ &= 25.35 / 5.21 \times 100 = 487 \text{ mg HC/ g TOC} \end{aligned}$$

From these data the kerogen transformation ratio can be computed:

$$\text{Transformation ratio (in \%)} = (\text{HI}_{\text{original}} - \text{HI}_{\text{present}}) / \text{HI}_{\text{original}}$$

$$\text{TR (\%)} = (487-68) / 487 \times 100 = 86\%$$

A second example from the main gas-producing area (Newark East Field), the T.P. Sims #2 well, contains high thermal maturity Barnett Shale, as would be expected in this part of the basin. Measured vitrinite reflectance is 1.66%, and the average calculated vitrinite reflectance value from Tmax is 1.61%. It has high residual TOC values and very low remaining generation potentials and hydrogen indices. The average residual TOC is 4.45% and the remaining generation potential is 1.07 mg HC/g rock. Following the method above, the original TOC is calculated to be 6.95%, whereas the original hydrocarbon generation potential is 30.16 mg HC/g rock, and the original HI is 434. Thus, the transformation ratio (TR) is calculated to be 94%.

Calculated TR values using this method for all the wells are shown in Table 1. Note that some wells are not highly converted, thus calculation of original TOC values must be adjusted to the level of conversion. For example, at peak oil generation the TOC value is only reduced about 18% rather than 36%. The relationship between TR and vitrinite reflectance provides a method for chemical assessment of thermal maturity (Fig. 5). The plateau above 1.00%VR_o is due to the delay between primary oil generation and elevated rates for secondary cracking of oil (primarily paraffins in the case of the Barnett Shale) to gas. Secondary cracking of hydrocarbons begins at about 145°C, whereas kerogen cracking to hydrocarbons ends at about that same temperature. Until the secondary cracking rate begins to increase rapidly, there is a plateau in gas-to-oil ratios (GOR) and gas yields.

Of course quantitative changes are also accompanied by qualitative changes in the reaction products that are generated with increasing thermal maturity. The thermal oil window is defined as the thermal maturity zone where liquid hydrocarbons are the dominant product, although there is *always* associated gas formed in the oil window too (ca. 0.60%-1.00/1.20%Ro). The thermal condensate-wet gas window is defined as the zone where light liquids and gas are the predominant products and is near the boundary where any retained oil is cracked to lighter liquids and gas (1.0-1.4%Ro). The thermal dry gas window is defined as the zone where methane begins to dominate the products that are generated (>1.4%Ro).

This is demonstrated by laboratory analysis of the products evolved from the Barnett Shale at various thermal maturities. Thermal extraction gas chromatographic (TEGC) fingerprinting allows the types of product contained within shale to be documented, although this does not include any lost gas (Jarvie et al., 2001).

In addition, measurement of the reaction products during compositional kinetic and yield assessments of the Barnett Shale can be extrapolated to various temperatures and maturities. Black oil and condensate-range hydrocarbons are the principal products generated in the oil window with estimated equivalent vitrinite reflectance values of 0.60 to 1.00%VR_o. Above about 1.00% VR_o, the predominant product is wet gas (C₂-C₄ hydrocarbons) and gas accounts for 50% of the product distribution. Above about 1.40%

Ro, methane becomes the predominant hydrocarbon that is formed from kerogen. In addition, at temperatures greater than about 145-150°C, any retained oil will also begin to crack at about 1.0%VR_o (depending on the heating rate) and the yield of gas will increase exponentially from that point forward.

Present-day temperatures at the Barnett Shale level are certainly not at the temperatures necessary to crack organic matter of any form, whether kerogen or oil; however, maximum paleo-temperatures were much higher. Based on offsets in vitrinite reflectance data in the Mississippian, it is estimated that approximately 5,500 ft. of erosion has occurred (Fig. 6), although it may be speculated that more or less erosion has also occurred based on the distribution of measured vitrinite reflectance values. While it is not known how much Permian section has been eroded, one can certainly identify thousands of feet of Permian sediments in the Permian Basin just to the west of the Ft. Worth Basin. Thus, due to the hypothesized deeper burial and temperature exposure, the Barnett Shale was likely at one time in the temperature regime of 150-190°C in the Newark East Field.

These temperatures also may have been attained or aided by hydrothermal events as speculated by Bowker (2002; 2003) and Pollastro and others (2003; 2004). These authors speculate that the Ouachita Thrust forced hot fluids through the Ellenburger heating the overlying Barnett Shale to higher temperatures than could be accomplished by depth of burial. The presence of saddle dolomites that have been found in the Chappel Formation in the southwestern portion of the basin and in the Hardeman Basin to the northwest as well as native cooper are cited as evidence for this hydrothermal event (Bowker, 2002; 2003).

Burial and thermal history models show that the Barnett Shale is in the oil window in the north (Truitt #1 well, Montague County), but is in the gas window based on models of the Gage #1 well in Johnson County and the Alice E. Allen Heirs well in Eastland County (Figs. 7a-c).

Burial and thermal history models show hydrocarbon generation from the Barnett Shale occurred as early as 250 m.a.b.p. (Figs. 7a-c). Unconformities are first estimated from geological data and then optimized using geochemical data especially vitrinite reflectance. These models utilize Barnett Shale kinetic parameters (rate data for the decomposition of Barnett Shale kerogen) and show the highest level of oil or gas generation at maximum paleo-temperatures. The Barnett Shale contains a low sulfur kerogen and generates oil and gas at slightly higher temperatures than sulfur or sulfur/oxygen rich kerogens such as carbonates (Fig. 8). The calculated transformation rate curves of figure 8 show the conversion of organic matter at increasing temperature using an arbitrary constant heating rate of 3.3°C/m.y. This illustrates that the rates of organic matter decomposition are variable and dependent on the composition as well as the structure of the organic matter. The rate of transformation for the Barnett Shale is typical of low sulfur, marine kerogens.

Note that while the grayscale shading (see Figs. 7a-c) shows the Barnett Shale to be in the oil or gas windows present-day, this only reflects maximum burial paleo-temperature, as it is not currently generating any hydrocarbons based on present-day temperatures.

Barnett Shale Gas Reservoir Yield

An important aspect of any gas shale or unconventional gas play is the need for gas yield data, i.e., the amount of gas that can be released from the rock in scf/ton. Typically, this analysis is done on core samples collected at the well site in canisters, but an approach using cuttings in gas impermeable bottles (Iso-Jars) has provided comparable yields in the Barnett Shale (Fig. 9). This does not eliminate the need for core tests, but it does mean that these analyses can be provided on a much broader scale since the cost is much less (no coring, inexpensive analysis).

There is also a need to understand how gas is stored in the Barnett Shale. Sorbed gas refers to gas stored in either an adsorbed or absorbed state. In adsorption, the gas is physically or chemically attached to the inorganic or organic matrix in the rock. A physical attraction is a physico-chemical bond that is relatively weak. A chemical bond is quite strong and there is no evidence for this type of bond in the Barnett Shale. Absorption refers to gas in solution with a solute, such as solution gas. Thus, the term sorbed is often used to describe the gas stored in the Barnett Shale without differentiating by which process it is held.

Experimental data acquired by monitoring the gas released from the mud gas (lost gas) versus the gas that desorbed from cuttings both before and after crushing provides an indication of gas yields. From one well the lost gas accounted for about 43% of the total gas. The gas that desorbed was equal to about 18% of the gas, whereas the gas released upon crushing of the cuttings accounted for the last 39% of the gas. This suggests that about 43% of the gas is free gas, 39% is sorbed gas, and the remaining 18% is a combination of free and sorbed gas that would only be released upon further stimulation such as fracturing an interval.

Gas adsorption data published by GRI (GRI report May 1991) was reworked by the senior author subjectively eliminating bad data points, i.e., adsorption yields that decreased with increasing pressure. These data provide sufficient information to evaluate gas yields at reservoir pressures, which are approximately 3800 psi in the Barnett Shale. There is inherent variability in the total and adsorbed gas yields within the Barnett Shale as shown by 2 sets of data (Fig. 10). From 9 different sets of reworked experimental data, the total gas yields range from 170-250 scf/ton, whereas the adsorbed gas ranges from 60-125 and the free gas from 110-125 scf/ton (by difference). Gas storage appears to be related to the mineralogy of the interval as the TOC values are typical of high maturity Barnett Shale samples (about 4.50%) except for one sample. The T.P. Sims lithology log shows considerable variation ranging from clay rich to silica rich zones. Similarly, available mineralogy data published by GRI on the W. C. Young #2 well that was also studied by the GRI (GRI report May 1991) shows a range of mineralogical composition ranging from 0 to 54% clay, 4 to 44% quartz, 0 to 78% calcite, and other

minerals such as pyrite, apatite, dolomite, and minor amounts of other minerals (Table 2). The TOC values are very consistent in this interval so the variability in gas contents and how it is stored appears to be more likely a function of the variable mineralogy. Other reports, however, have shown a near perfect correlation of TOC to gas yields (Dougherty, 2004, *personal communication*) when sample testing was well constrained.

It was also noted from a gas database that there was a relationship between gas calorific value (in BTUs) and gas dryness (Fig. 11). Gas dryness is defined as the ratio of methane to the sum of methane, ethane, propane, and butane (C₁, C₂, C₃, i-C₄, and n-C₄ gases, respectively). These data show a 0.78 least squares correlation despite the gases containing variable amounts of carbon dioxide and nitrogen that lower the BTU values. Since pure methane has a BTU value of 978, any gas having greater than 90% gas dryness ratio is inferred to be in the dry gas window. Gases having 80% gas dryness are inferred to be in the condensate-wet gas window, and gases with less than 80% gas dryness (i.e., they are wetter) are oil window. This inferred relationship *only applies* to gases in a self-sourcing gas habitat such as the Barnett Shale. Thus, from these data another thermal maturity parameter is available for assessment of gas risk and one that can be used *while drilling or in near while drilling time frames from mud gas or bottled cuttings gas analyses*.

Risking Shale Gas Prospects, Plays, or Basins based on Geochemical Data

A basic approach to performing shale gas risking assessments is to determine and map organic richness, kerogen type, kerogen transformation, various thermal maturity parameters, gas contents, and gas yields. To complete this, only TOC, Rock-Eval, vitrinite reflectance, and gas data are needed. However, there may be conflicts in the data due to a variety of circumstances such as poor vitrinite maceral yields, misidentification of indigenous vitrinite populations, bitumen staining (Landis and Castanet, 1995), unreliable Tmax data and so forth. The first and most important step is to understand the type of petroleum system that is present. For example, parameters that point to success in the thermogenic Barnett Shale gas play will not work in the Antrim Shale gas play, which is a biogenic gas play. In addition, some basic assessments must be made as to what products are generated at a given thermal maturity. Thus, a basic investigation and understanding of the petroleum system with respect to source rock thermal maturity, its extent of conversion, the timing of generation and expulsion, and oil and gas analyses must be undertaken. A large dataset also helps integrate and evaluate specific prospect data.

Once this is undertaken, conflicts in the data may arise. One method of assessing these data is a simple polar plot (Hill plot) setting specific guidelines for the gas window. In the case of the Barnett Shale, the following risking minimum values for prospective gas production are suggested (Fig. 12):

TOC:	2.00%
TR:	80%
Tmax:	455°C

VR_o: 1.0%
Gas dryness: 80%

There may be critical cross-over points that need to be more accurately determined such as vitrinite reflectance; most geochemists would argue for at least 1.20%VR_o, but there is a dependency on sample type (i.e., cuttings vs. core). Thus, the range of 1.00 to 1.20% could be considered a questionable maturity range for finding productive gas.

Identifying sweet spots

The phrase “sweet spots” is used by many in two different ways: (1) to identify the best geographic areas within a basin for gas, and (2) to identify the best formation zones in a given well to complete. Here, we prefer the terminology “fairway” to describe basin wide trends. Thus, the best geographic areas for gas production would be termed gas fairways. The term sweet spot is then used to describe the most productive zones within the formation in a given well, or depth interval.

Well logging of mud gases and desorbed gases from cuttings or core are effective tools for identifying the best zones to complete. Yields will vary with TOC and with lithology. The Barnett Shale is principally siliceous shale, but also contains clay-rich shales, cherts, and dolomitic lithologies (Henk, 2000; GRI report May 1991). These lithofacies variations (lithology and TOC) will affect producible yields, whether oil and gas in lower thermal maturity prospects or high BTU to low BTU gas in higher thermal maturity prospects. In addition it has been reported that the most highly fractured Barnett Shale intervals in and near the Newark East Field have among the poorest hydrocarbon yields for gas (Bowker, 2002; 2003).

Quantitative analysis of mud gases, headspace gases in canned cuttings, and production gases has shown that gas dryness is an excellent indicator of thermal maturity and provides yields of gas per unit of rock. Of course, adsorption tests on core and desorption tests on sidewall cores (SWC) corroborate and enhance the interpretation of these analyses. Mud gases will always be drier than canned cuttings gases due to higher rates of desorption and diffusion of dry gas (methane) out of the reservoir into the well bore (lost gas) and retention of the wetter gases (ethane, propane, and butanes) or gas that will desorb through time (desorbed gas). There are also solubility differences that may affect these differences. Back calculation from longer term desorption testing can be used to calculate lost gas, but quantitative mud gas yields provide a direct indication of lost gas. In many reservoir types, the mud gas is more representative of the actual products in the reservoir (e.g., unconsolidated sands of the Gulf of Mexico, Patience, 2003). However, when evaluation of low permeability shales is undertaken, both mud gas and desorbed gas must be quantitatively determined. In addition there is additional gas yield when the shale is completed by water or proppant fracturing operations and this is evaluated by crushing the sample and measuring the released gas.

Gas yields from mud gas and desorbed gases from canned cuttings samples can be made available to assess well specific sweet spots for the best productivity of oil, wet gas, or dry gas. This is a simple assessment of gas dryness from a ratio of methane to the total gas consisting of methane, ethane, propane, and butanes ($C_1 / (C_1-C_4)$). This classical approach is quite effective in evaluating different horizons for producibility characteristics (Pixler, 1962). A correlation of gas dryness to thermal maturity and the calorific values for Barnett produced oil or gas was demonstrated by Jarvie et al. (2003).

Conclusions

The Barnett Shale is organic rich, but TOC values in the dry gas zone have values decreased by about 36% due to loss of carbon from kerogen in the form of hydrocarbons. Likewise, in the gas generation window, the kerogen type will only reflect the present-day potential of the shale, which is gas prone for any thermally mature rock. However, the original potential of the Barnett Shale, as determined from thermally immature samples from outcrop and well samples, firmly establishes it as a Type II oil prone, marine shale with an original HI value of about 487 mg HC/g TOC. The Barnett Shale generates gas in the oil generation window, but this only constitutes about 30% of the total hydrocarbons generated with the rest being liquids (C_5+). Because of the low permeability, limited porosity, and retentive capacity of the Barnett Shale, some hydrocarbons are retained during primary migration. This leads to retention of oil until it is cracked to gas.

Burial- and thermal- history models suggest that the Barnett Shale entered the gas generation window approximately 250 ma; it is thought that little, if any, additional generation has occurred in the last 250 m.y. There are assumptions in the models that may allow more gas generation in the last 25 m.y. but the present model shows much earlier gas generation.

Gas data may be used to predict thermal maturity, as shown by correlation of gas dryness to BTU content of produced gases in the basin.

The Barnett Shale has very high gas yields ranging from 170-250 scf/ton based on corrected methane adsorption data from the T.P. Sims #2 well. This gas is present as 55% free gas and 45% sorbed gas, on average. However, there is considerable variability in these yields depending on the interval analyzed within the Barnett Shale. This variability is hypothesized to be due to variations in porosity and mineralogy as the TOC values are quite similar in most of the samples. However, a low TOC sample (0.47%) included in the analysis certainly does have the lowest gas yield, but TOC does not explain the variable gas yields in the organic rich zones that average 4.45% TOC with small variance.

Various geochemical parameters can be used to assess a prospect for its gas potential based on the thermal maturity of a basin, lease area, or prospect. These include TOC, TR and Tmax data (derived from Rock-Eval analysis), vitrinite reflectance, and gas data. Gas isotopes and condensate/oil chemistry can also be used to map out maturity regimes.

Acknowledgements

Much advance to the Ft. Worth Basin work has transpired in the past year by a collaborative effort between Humble and geochemists and geologists from the U.S. Geological Survey in Denver. These people include Paul Lillis, Augusta Warden, and Dave King at the USGS. Also my colleagues at Humble contributed immensely to this effort especially Jack D. Burgess and a consultant, Brenda L. Claxton.

References

Bowker, K.A., 2002, Recent developments of the Barnett Shale play, Fort Worth Basin; in Law, B.E. and Wilson, M., eds., Innovative Gas Exploration Concepts Symposium: Rocky Mountain Association of Geologists and Petroleum Technology Transfer Council, October, 2002, Denver, CO, 16 p.

-----, 2003, Recent development of the Barnett Shale play, Fort Worth Basin; West Texas Geological Society Bulletin, v. 42, no. 6, 8 p.

Espitalie, J., M. Madec, and B. Tissot, 1984, Geochemical logging, in K. J. Voorhees, ed., Analytical pyrolysis – techniques and applications: Boston, Butterworth, pp. 276-304.

Gas Research Institute Report *entitled* Formation Evaluation Technology for Production Enhancement: Log, Core, and Geochemical Analyses in Barnett Shale, Mitchell Energy Corp. Thomas P. Sims No. 2, Wise County, Texas, May 1991, Gas Shale Project Area, GRI Contract No. 5086-213-1390.

Henk, Floyd "Bo" and John T. Breyer, 2000, Lithofacies, Petrography, and Geochemistry of the Barnett Shale in Conventional Core and Outcrop, Barnett Shale Symposium, Sept. 28, 2000, Ft. Worth, Texas, *oral presentation*.

Hill, R.J., D.M. Jarvie, R.M. Pollastro, K.A. Bowker and B.L. Claxton, 2004, Geochemistry of an unconventional gas prospect: The Barnett Shale gas model, Goldschmidt Conference, June 7-11, 2004, Copenhagen, Denmark, *oral presentation*.

Jarvie, D.M. and Lundell, L.L., 1991, Hydrocarbon generation modeling of naturally and artificially matured Barnett shale, Ft. Worth Basin, Texas, Southwest Regional Geochemistry Meeting, Sept. 8-9, 1991, The Woodlands, Texas, 1991.

Jarvie, D.M., 1991, Total Organic Carbon (TOC) Analysis, in Treatise of Petroleum Geology, Handbook of Petroleum Geology, Source and Migration Processes and Evaluation Techniques, Ed. R.K. Merrill, AAPG Press, Tulsa, Ok.

Jarvie, Daniel M., 2000, Assessment and Prediction of Hydrocarbon Generation of the Barnett Shale, Barnett Shale Symposium, Sept. 28, 2000, Ft. Worth, Texas, *oral presentation*.

Jarvie, Daniel M., Brenda L. Claxton, Floyd "Bo" Henk, and John T. Breyer, 2001, Oil and Shale Gas from the Barnett Shale, Ft. Worth Basin, Texas, AAPG National Convention, June 3-6, 2001, Denver, CO, AAPG Bull. Vol. 85, No. 13 (Supplement), p. A100.

Jarvie, Daniel M., Ronald J. Hill, Richard M. Pollastro, David A. Wavrek, Kent A. Bowker, Brenda L. Claxton, and Mark H. Tobey, 2003, Evaluation of Unconventional

Natural Gas Prospects: the Barnett Shale fractured shale gas model, 21st IMOG Meeting, Krakow, Poland September 8-12, 2003, *poster presentation*.

Jarvie, Daniel M., Ronald J. Hill, Richard M. Pollastro, David A. Wavrek, Kent A. Bowker, Brenda L. Claxton, and Mark H. Tobey, 2004, Assessment of the Gas Potential and Yields from Shales: the Barnett Shale Model, Unconventional Gas of the Southern Mid-Continent Symposium, March 9-10, Oklahoma City, OK, *oral presentation*.

Landis, Charles R. and John R. Castaño, 1995, Maturation and bulk chemical properties of a suite of solid hydrocarbons, *Org. Geochem.*, Vol. 22, No., pp. 137-149.

Magoon, L.B., and Schmoker, J.W., 2000, The total petroleum system: The natural fluid network that constrains the assessment unit, in U.S. Geological Survey world petroleum assessment 2000. Description and results: U.S. Geological Survey Digital Data Series DDS-60, p. PS1-PS20.

Montgomery, Scott L., Daniel M. Jarvie, Kent A. Bowker, and Richard M. Pollastro, 2004, Mississippian Barnett Shale, Fort Worth Basin, North-Central Texas: Gas-Shale Play with Multi-Tcf Potential, *AAPG Bull.*, E&P Note, *in press*.

Patience, Richard, 2003, Comparison of Subsurface Gas Data from Different Sampling Methods, 21st International Meeting on Organic Geochemistry, September 8-12, Krakow, Poland, Book of Abstracts Part II, p. 7.

Pixler, B.O., 1969, Formation Evaluation by Analysis of Hydrocarbon Ratios, *Journal of Petroleum Technology*, pp. 665-670.

Pollastro, R.M., 2003, Geological and production characteristics utilized in assessing the Barnett Shale continuous (unconventional) gas accumulation, Barnett-Paleozoic Total Petroleum System, Fort Worth basin, Texas: Barnett Shale Symposium, Ellison Miles Geotechnology Institute at Brookhaven College, Dallas, Texas, November 12-13, 2003, 6 p.

Pollastro, R.M., R.J. Hill, D.M. Jarvie, and M.E. Henry, 2003, Assessing undiscovered resources of the Barnett-Paleozoic Total Petroleum System, Bend Arch-Fort Worth Basin Province, Texas (abs.): AAPG Southwest Section Convention, Fort Worth Texas, March 1-5, 2003, 18 p.

Pollastro, R.M., Hill, R.J., Jarvie, D.M., and Adams, C., 2004, Geologic and organic geochemical framework of the Barnett-Paleozoic Total Petroleum System, Bend Arch-Fort Worth Basin, Texas [abs.]: Abstracts Volume, 2004 American Association of Petroleum Geologists Annual Convention, Dallas, TX, p. A113 [CD-ROM]

Map No.	Well Name	TOC	HI	Potential Yields (BO/AF or MCF/AF)	Tmax	Cal. VRo	Meas. %VRo	Cal. TR
1	Mitcham #1	4.67	396	405	434	0.65	nd	0%
2	Heirs #1	3.40	68	51	454	1.01	0.9	83%
3	T.P. Sims #2	4.45	25	24	487	1.61	1.66	94%
4	W. C. Young #1	4.93	56	60	468	1.26	nd	86%
5	Oliver #1	4.30	13	12	544	2.63	nd	97%
6	Truitt A #1	4.13	261	236	445	0.85	nd	34%
7	Grant #1	4.70	299	309	446	0.86	nd	35%
8	Gage #1	2.66	39	23	485	1.57	1.37	90%
9	Lampasas Outcrop Sample 1	13.08	463	1326	430	0.58	nd	0%

Depth (feet)	Total Clay	Quartz	K Feldspar	Plagioclase	Calcite	Dolomite	Pyrite	Apatite	Total	TOC
6090.50	16	10	0	0	55	17	2	0	100	nd
6920.00	35	44	1	2	4	7	4	3	100	4.84
6936.00	43	30	1	2	2	3	6	13	100	nd
6944.00	4	13	0	1	54	3	11	14	100	nd
6953.50	37	40	0	3	4	1	7	8	100	nd
6964.00	4	10	0	3	78	2	3	0	100	nd
6973.00	38	37	2	6	3	2	5	7	100	nd
6985.00	42	38	1	3	2	3	8	3	100	nd
7001.00	23	32	0	4	30	4	4	3	100	nd
7006.00	37	34	1	6	10	6	2	4	100	nd
7007.00	0	4	0	2	71	1	21	1	100	nd
7014.00	31	42	1	4	7	7	6	2	100	nd
7022.50	20	33	0	5	3	0	10	29	100	nd
7026.00	48	33	2	6	0	1	8	2	100	nd
7030.50	7	4	1	4	5	70	9	0	100	nd
7033.00	48	36	4	5	0	1	4	2	100	4.42
7045.00	37	40	2	4	2	8	5	2	100	nd
7061.60	41	42	2	3	3	3	5	1	100	nd
7065.00	45	40	1	4	0	2	6	2	100	nd
7075.00	37	43	1	4	3	3	6	3	100	nd
7081.00	18	17	0	4	2	55	4	0	100	1.88
7086.00	54	31	1	4	0	0	7	3	100	5.16
7095.00	46	34	0	4	0	5	9	2	100	nd
7108.00	32	31	3	4	2	20	6	2	100	5.78
7118.00	51	28	5	6	0	0	7	3	100	nd
7126.00	37	47	2	4	0	1	5	4	100	6.53
7135.00	48	33	3	5	0	3	7	1	100	nd
7141.00	45	34	1	3	3	4	6	4	100	nd
7150.00	50	34	2	4	0	0	8	2	100	nd
7156.50	21	23	1	2	42	3	4	4	100	nd

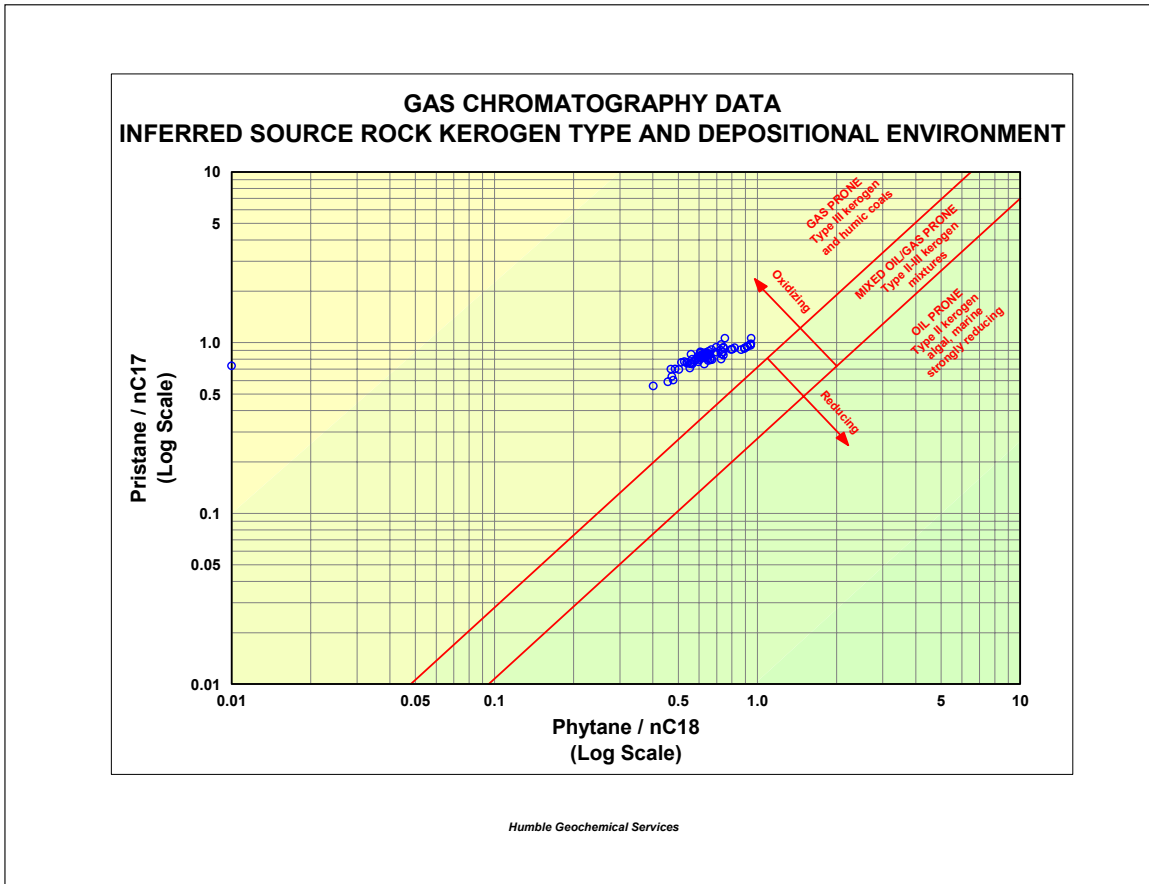
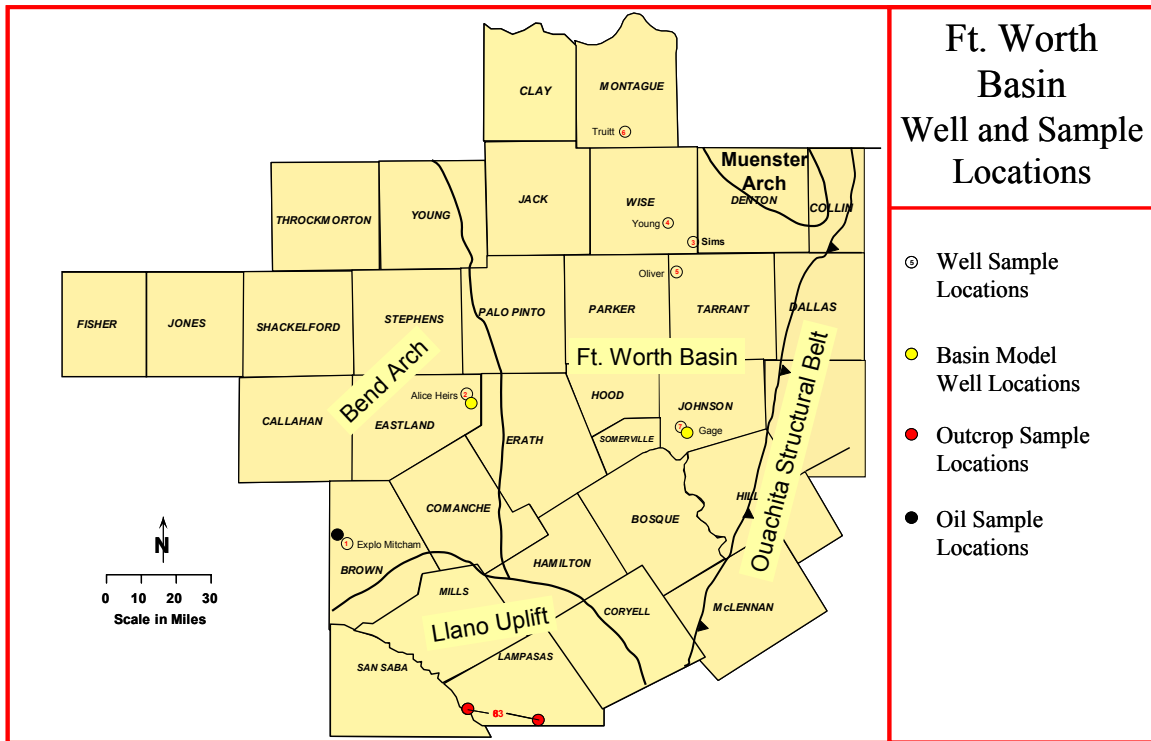

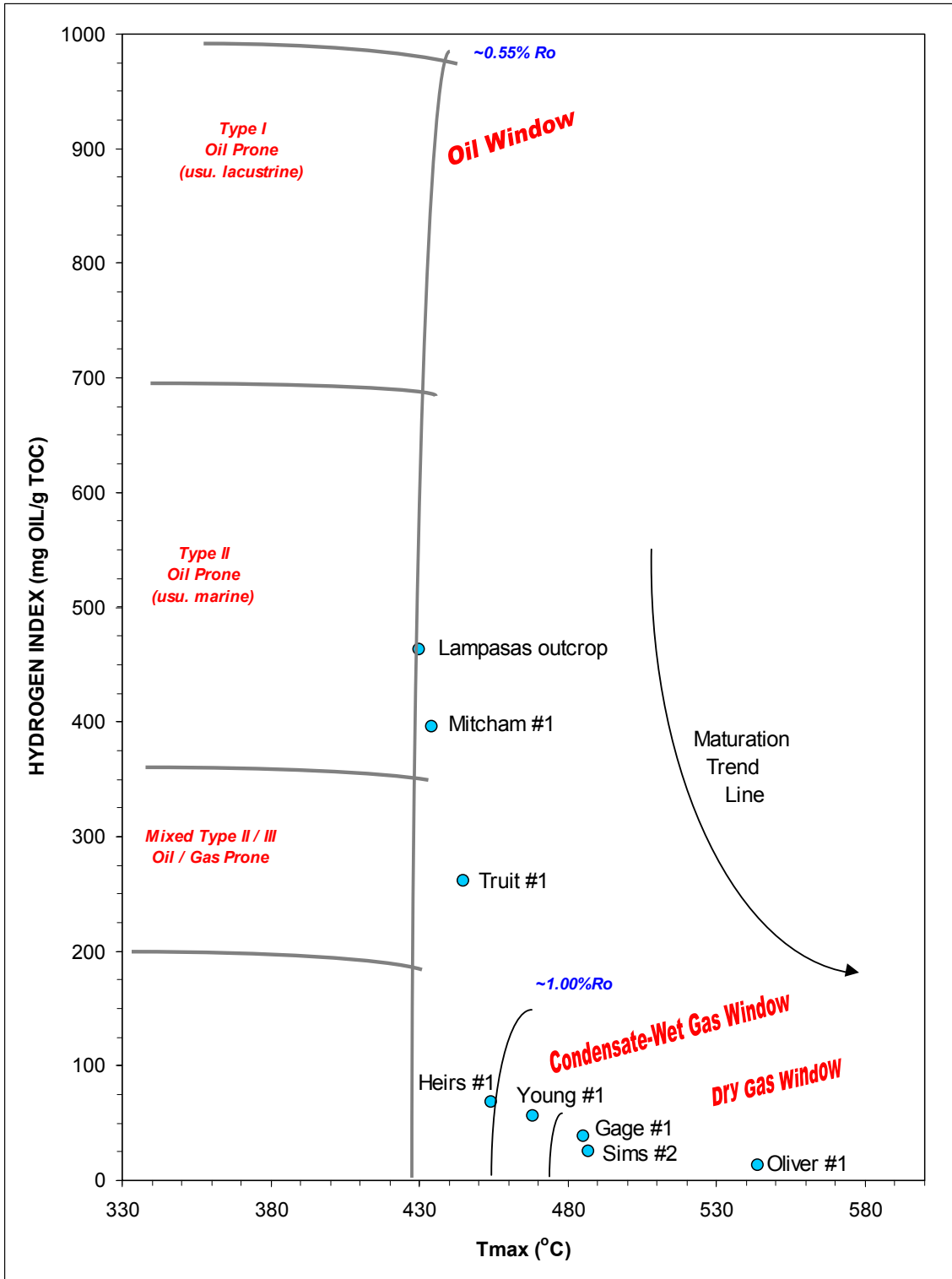

Mitcham #1

A.E.A. Heirs #1

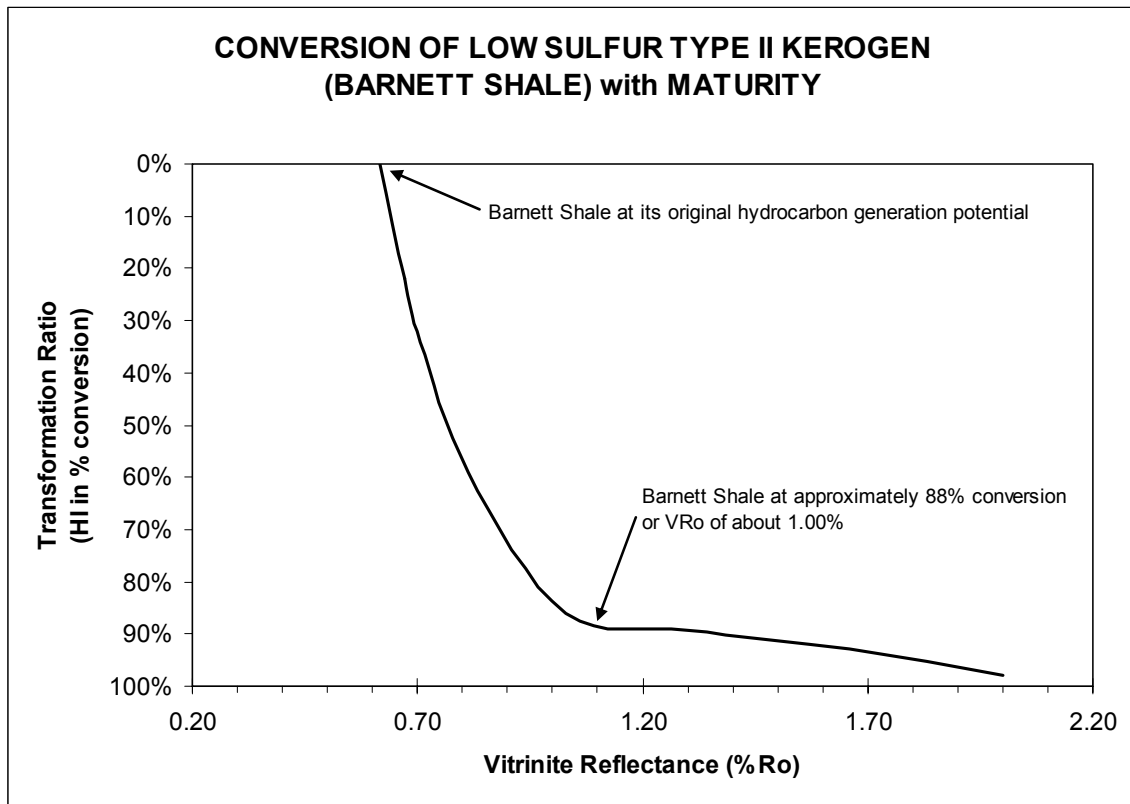
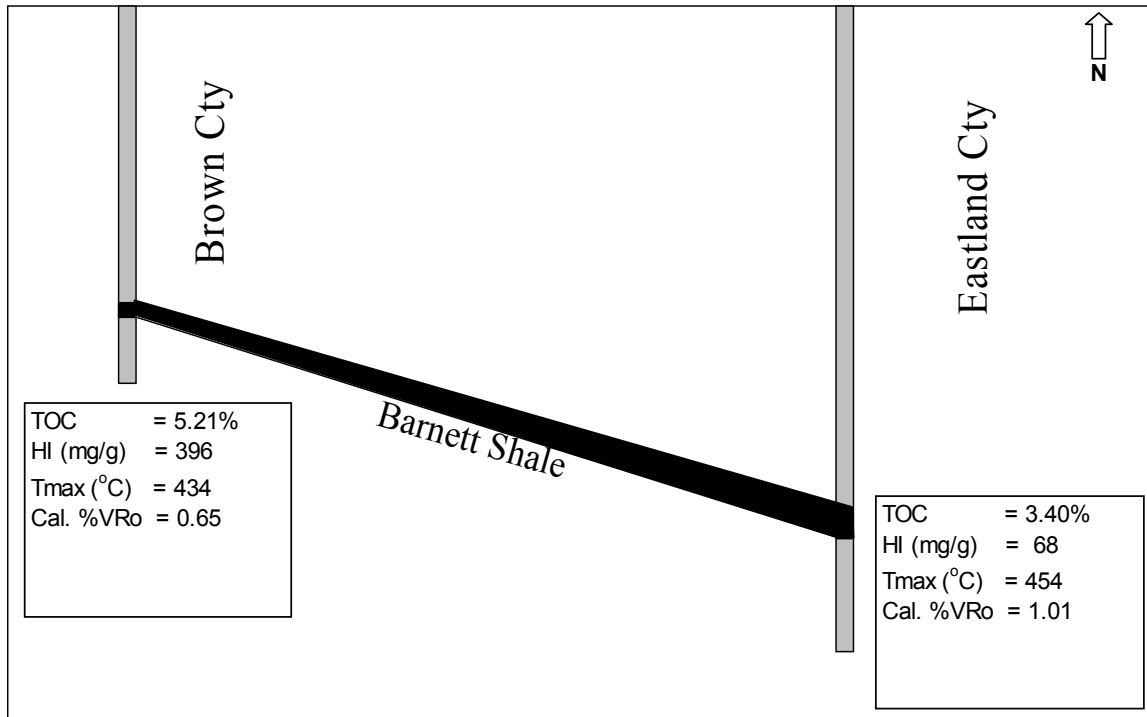

Denton, Tarrant & Wise Counties

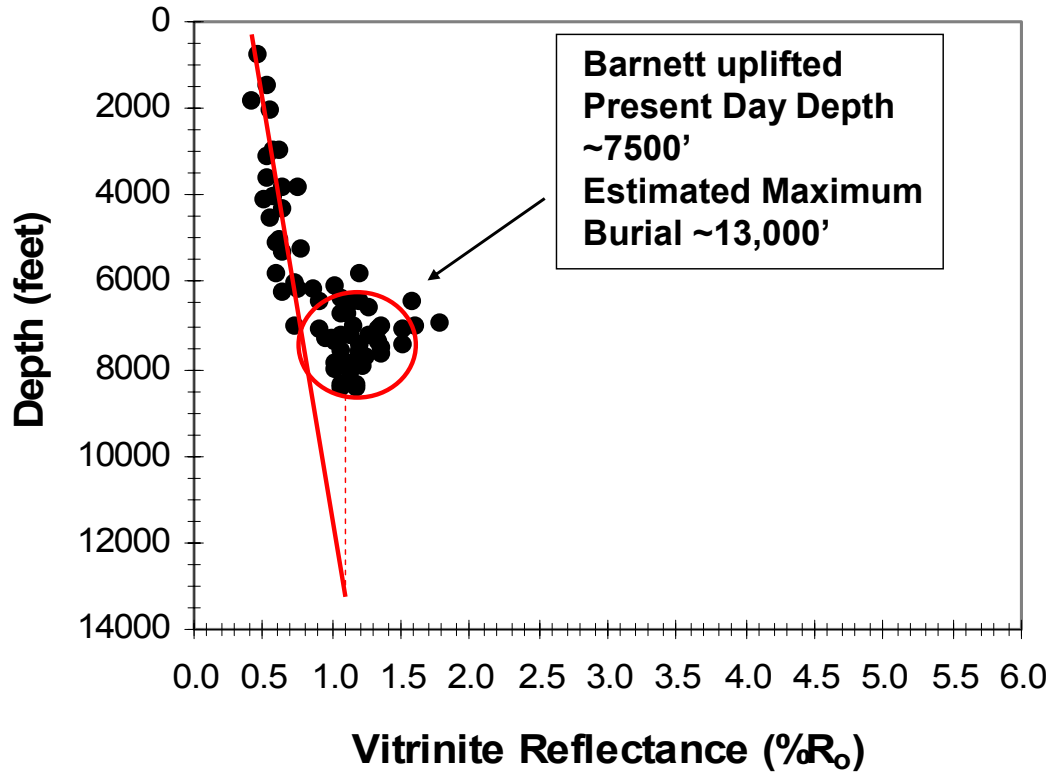

Johnson County

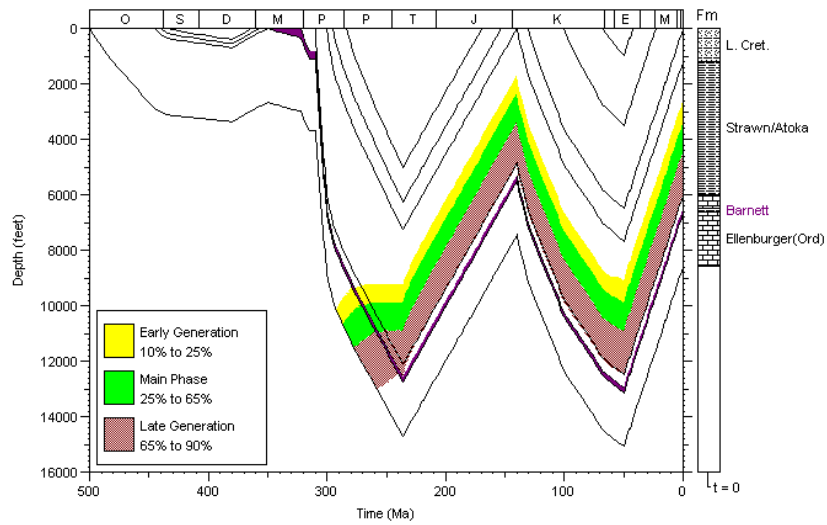

Montague County

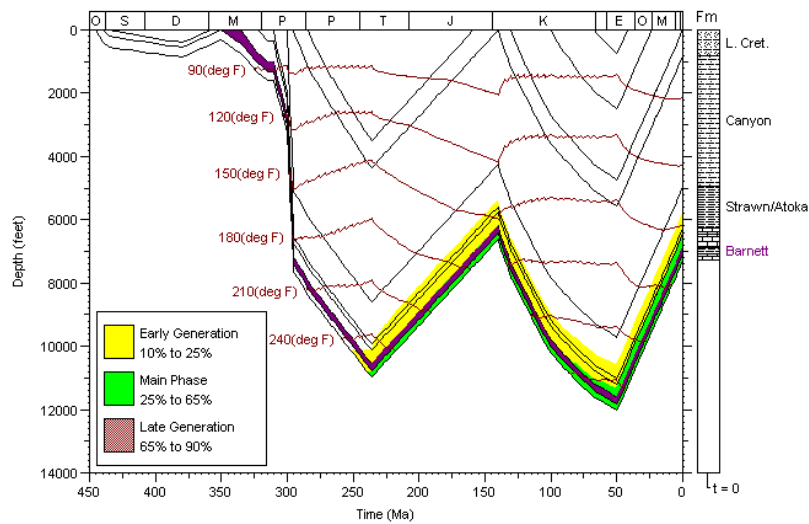

Eastland County

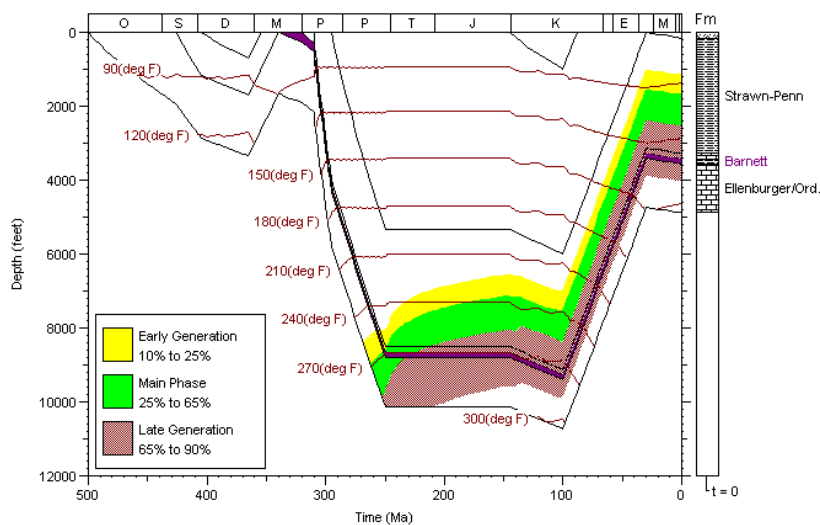

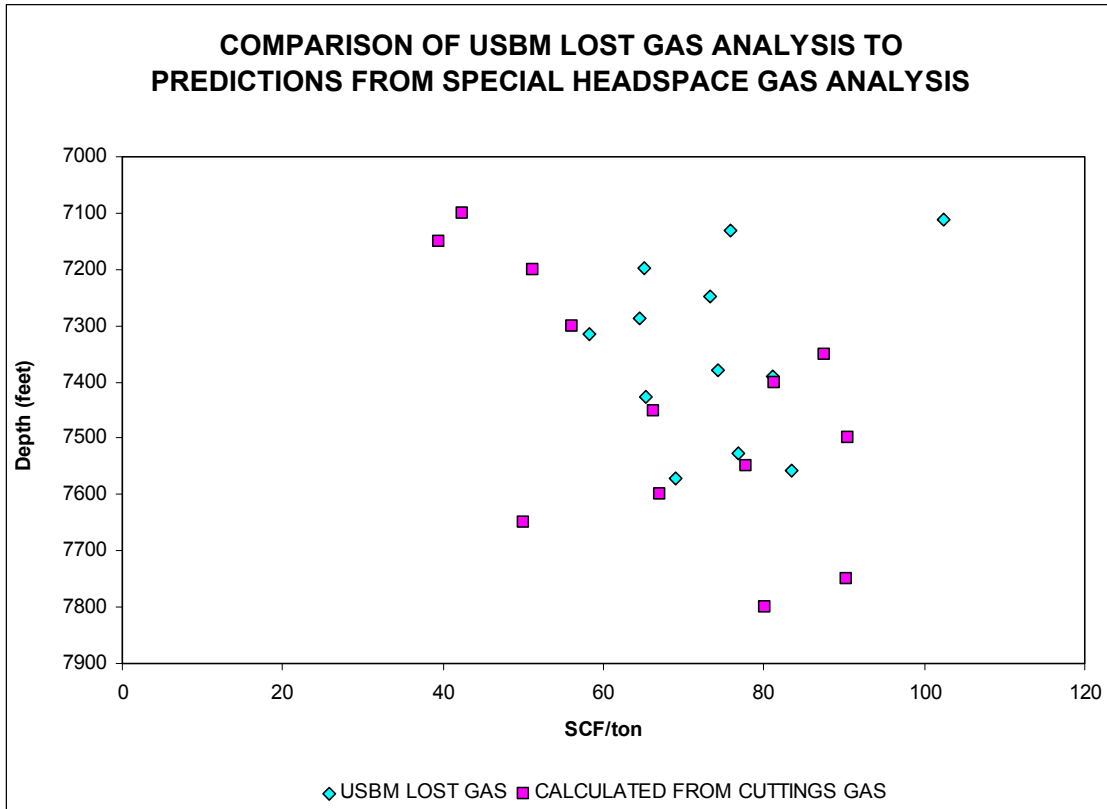
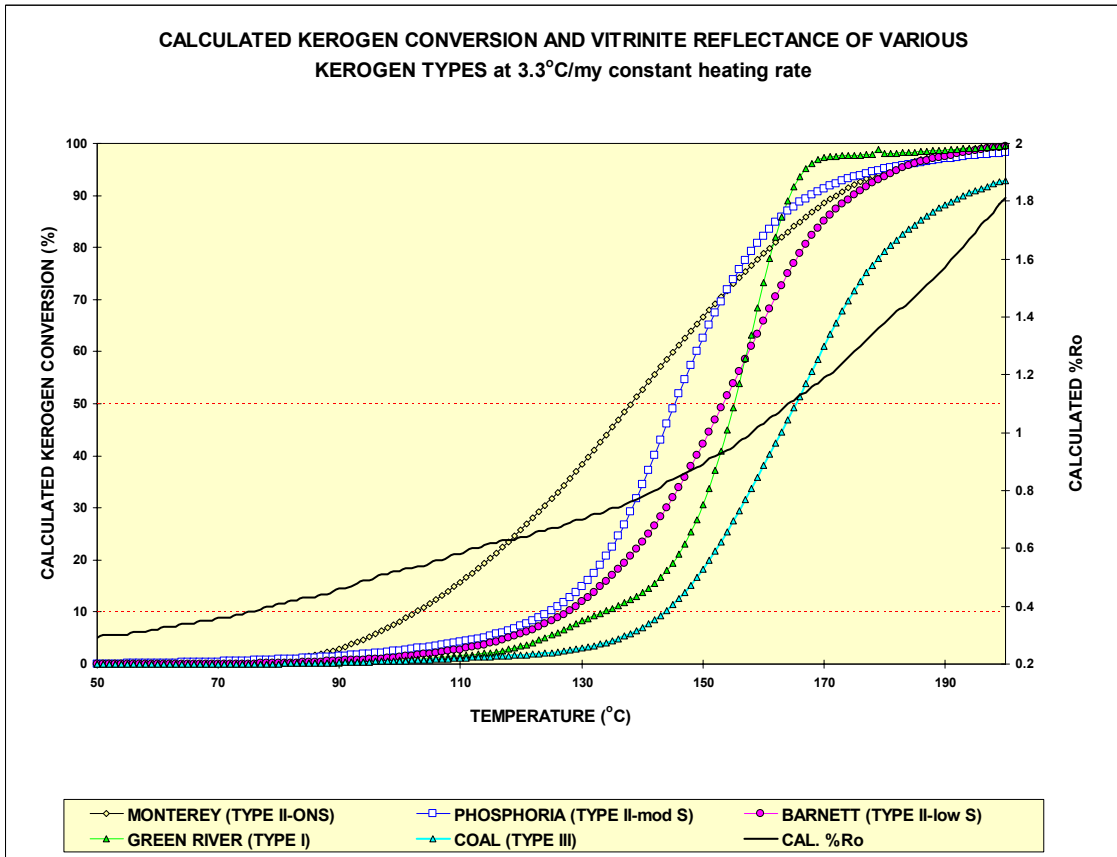

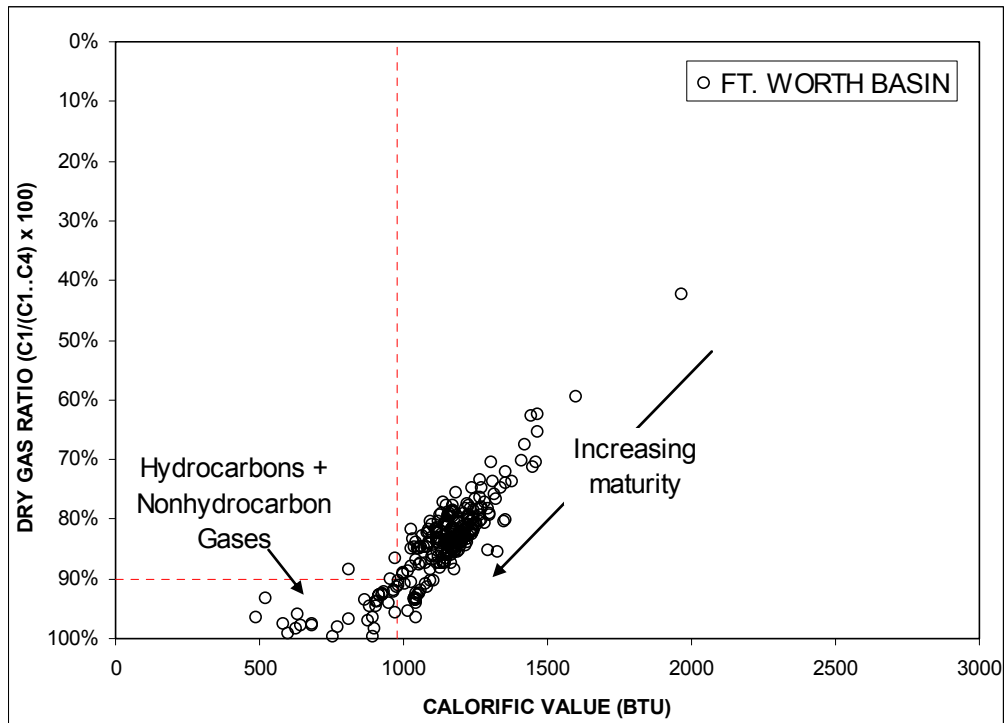
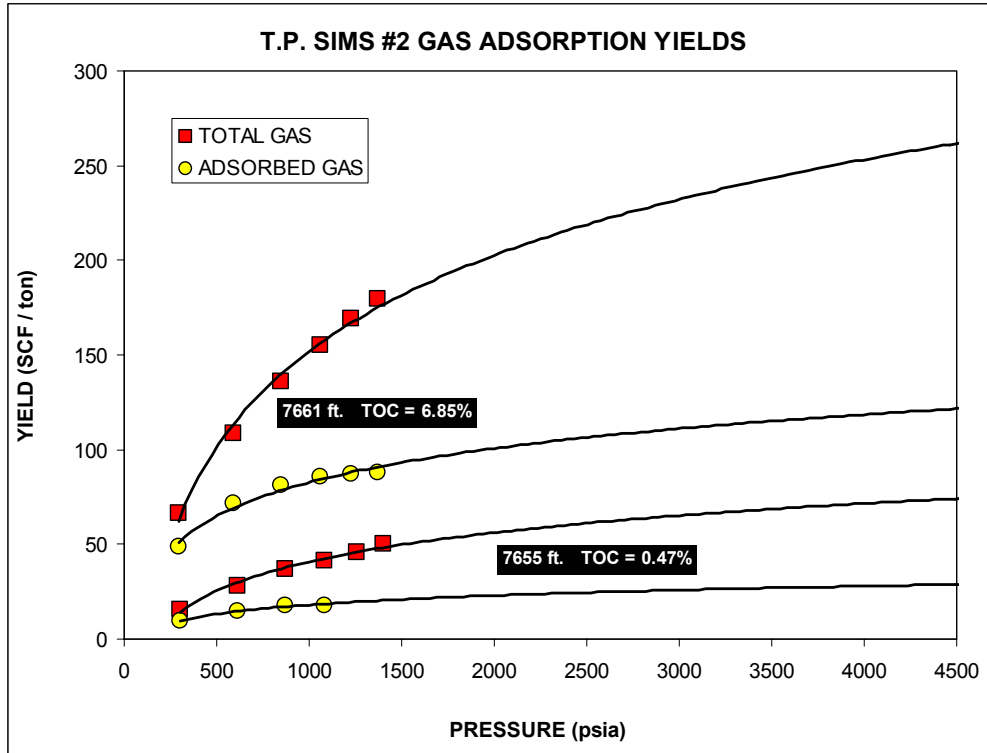

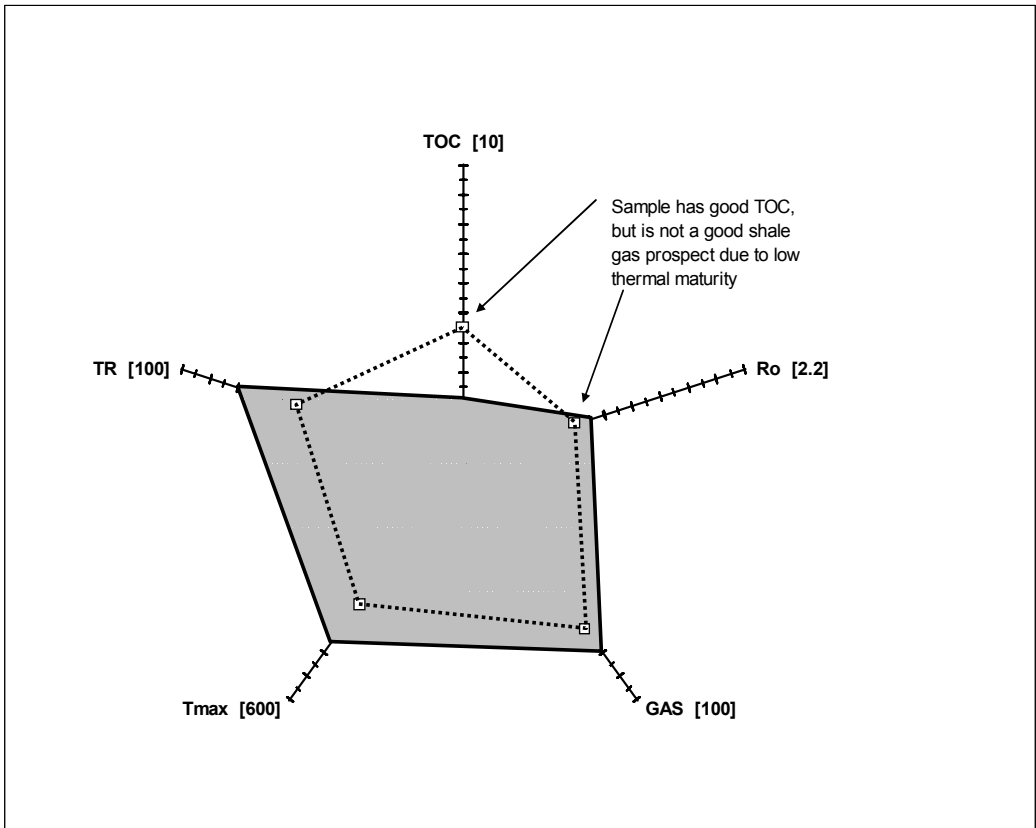
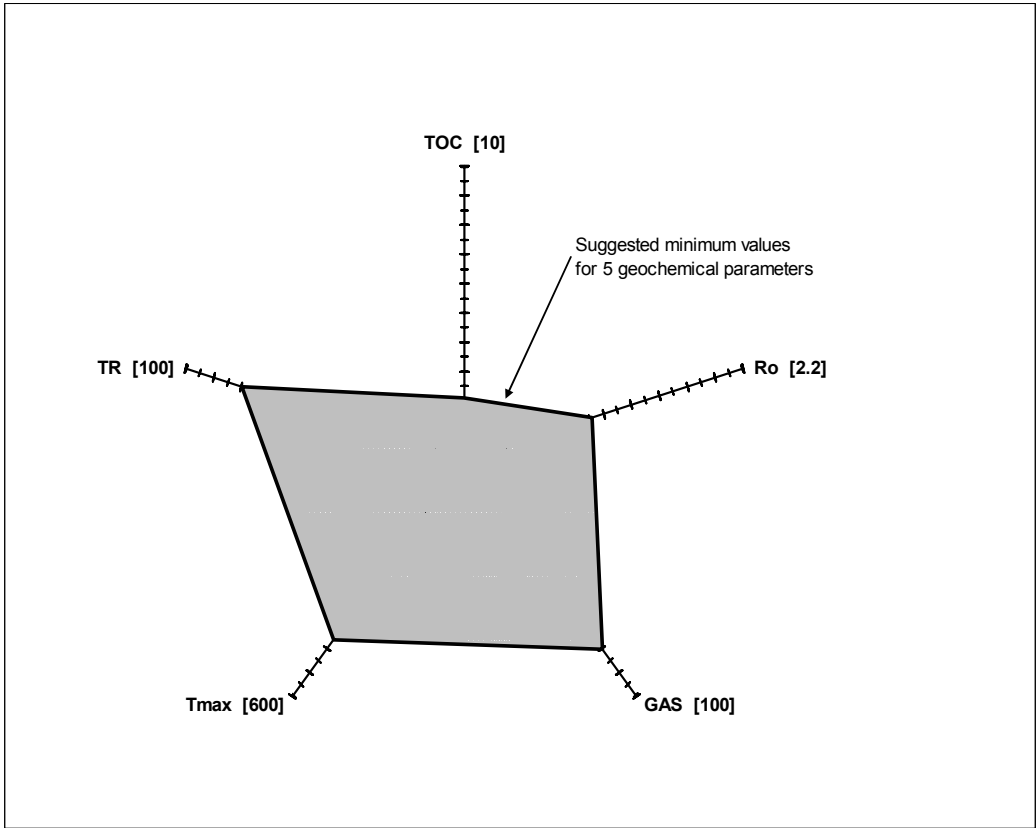

Figure Captions.

Figure 1. Generalized structural and sample location map for wells and outcrop samples.

Figure 2. Classical plot of isoprenoid biomarkers normalized to adjacent normal paraffins showing a high degree of similarity among 70 oils from around the Ft. Worth Basin.

Figure 3. A modified Espitalie kerogen type and maturity (Espitalie et al., 1984) plot showing immature through post mature Barnett Shale samples from various wells with varying burial and thermal histories across the Ft. Worth Basin.

Figure 4. A schematic cross-section between the Mitcham #1 well in Brown County and the down-dip A.E. Allen Heirs #1 well in Eastland County with measured geochemical parameters.

Figure 5. Relationship of Barnett Shale kerogen transformation to measured vitrinite reflectance values. As thermal maturity increases, kerogen transformation or conversion to hydrocarbons, also increases.

Figure 6. Vitrinite reflectance data from Denton, Tarrant, and Wise counties showing a variable dog-leg gradient from the Pennsylvanian section through the Barnett Shale. A mid-point drop point suggests about 5,500 ft. of erosion.

Figure 7. Burial and thermal history models of 3 wells in the Ft. Worth Basin. (a) the Gage #1 well in Johnson County shows gas window thermal maturity due to a very deep burial about 250 m.a.b.p.; (b) the Truitt #1 well in Montague County shows oil window thermal maturity due to significantly less burial and maximum temperature exposure for the Barnett Shale; (c) the Heirs #1 well shows early condensate-wet gas window thermal maturity and less erosion in the Paleozoic section.

Figure 8. Rates of organic matter conversion (transformation ratio in %) are variable and show the Barnett Shale to be more refractory than higher sulfur kerogens.

Figure 9. Correlation of USBM desorption gas yields to gas yields determined from bottled cuttings samples. Desorption gas yields from cuttings allow high density sampling and assessment of gas potentials.

Figure 10. Adsorption test results for a lean and organic rich Barnett Shale samples refit from adsorption data in the May 1991 GRI report and projected to 3800 psi, the typical reservoir pressure in a Barnett Shale well.

Figure 11. Relationship of calorific value of 77 gases from the Ft. Worth Basin to gas dryness ratio. Gas dryness can be determined from either production gases, mud gases, or cuttings headspace gases and can be used to infer thermal maturity of Barnett Shale.

Approximately 80% gas dryness is required for condensate-wet gas window thermal maturity, and over 90% for dry gas (lowest BTU hydrocarbon gas).

Figure 12. Geochemical risking parameters for thermogenic shale gas suggested from Barnett Shale studies. Samples exceeding these minimum values suggest a good prospect for shale gas production in a thermogenic gas play.